

## LIMITED LIFETIME WARRANTY

All Legend ® Suspensions' parts are guaranteed to the original purchaser to be free of manufacturing defects and workmanship. Parts that fail to conform to these conditions will be repaired or replaced at Legend ® Suspensions' option if the parts are returned to Legend ® Suspensions by the original purchaser. Delivery of the original purchase invoice or receipt along with the part to Legend ® Suspensions is a condition precedent to Warranty coverage. Warranty coverage is limited lifetime.

In the event the original purchaser believes warranty service is required, the original purchaser must call or e-mail Legend ® Suspensions immediately to discuss the concern. Some concerns may be rectified by a telephone call and need no further course of action.

A part that is suspect of being defective must not be replaced by a Dealer or any other person without prior written authorization from Legend ® Suspensions. If it is deemed necessary for Legend ® Suspensions to make an evaluation of the part to determine whether a defect exists, a return authorization number (RA#) must be obtained from Legend ® Suspensions by the original purchaser. Properly obtaining a return authorization number from Legend ® Suspensions is a condition precedent to Warranty coverage.

The part must be packaged properly so as to not cause further damage and be returned prepaid to Legend ® Suspensions with a copy of the original invoice or receipt of purchase. If after evaluation, Legend ® Suspensions finds the part to be defective, Legend ® Suspensions will repair or replace the part, at the discretion and option of Legend ® Suspensions.

### Exclusions

This warranty is void if:

- (1) the Legend ® Suspensions' part is repaired, modified, or altered, unless such repair, modification, or alteration is expressly authorized by Legend ® Suspensions in writing;
- (2) the Legend ® Suspensions' part becomes defective in whole or in part as a result of improper installation, improper maintenance, improper use, abnormal operation, or any other misuse or mistreatment of the Legend ® Suspensions' part;
- (3) the Legend ® Suspensions' part is installed or used in any motorcycle or other vehicle other than an Unmodified Factory OEM Motorcycle;
- (4) the Legend ® Suspensions' part is installed or used on any motorcycle or other vehicle being used in any form of competitive riding or racing, off road riding, or stunt riding. Stunt riding shall include, but not be limited to, any form of acrobatic maneuvering of the motorcycle, wheelies, stoppies, burnouts, jumping, or operating the motorcycle at an excessive rate of speed;
- (5) the Legend ® Suspensions' part is installed or used on any motorcycle or other vehicle being operated at a speed in excess of the speed allowed by any applicable law, regulation, or ordinance or is operated in any other manner in violation of any applicable law, regulation, or ordinance;
- (6) the serial or parts identification number of the Legend ® Suspensions' part is defaced or missing;
- (7) the Legend ® Suspensions' part is returned with no authorization number issued from Legend ® Suspensions; or
- (8) the original purchase invoice or receipt is not provided to Legend ® Suspensions along with the part.

### Additional Limitations

- (1) Legend ® Suspensions shall have no warranty or liability obligation to cover work shop labor charges incurred to install or remove suspension systems or individual components.
- (2) Electrical components are limited to a two-year manufacture's warranty from the original invoice date or installation.
- (3) Limited lifetime warranty as used within this warranty is further defined as the lifetime of the specific product line. Any product line that has been discontinued for which replacement parts are no longer available is not covered by this warranty.
- (4) The customer is liable for shipping charges to and from Legend ® Suspensions for warranty repairs or replacement parts consistent with this warranty.

LEGEND ® SUSPENSIONS (INCLUDING ITS SUBSIDIARIES, AFFILIATES, OFFICERS, DIRECTORS, EMPLOYEES, AGENTS OR SHAREHOLDERS) SHALL NOT, UNDER ANY CIRCUMSTANCES, WHETHER AS A RESULT OF BREACH OF CONTRACT, BREACH OF WARRANTY, TORT, STRICT LIABILITY, THE FAILURE TO DELIVER, DELAY IN DELIVERY IN NON-CONFORMING CONDITION, OR FOR ANY OTHER BREACH OF CONTRACT OR DUTY BETWEEN LEGEND ® SUSPENSIONS AND A CUSTOMER OR OTHERWISE, BE LIABLE FOR CONSEQUENTIAL, INCIDENTAL, SPECIAL OR EXEMPLARY OR PUNITIVE DAMAGES INCLUDING, WITHOUT LIMITATION, LOSS OF PROFITS OR REVENUES, LOSS OF OTHER GOODS OR ASSOCIATED EQUIPMENT OR DAMAGES TO ANY ASSOCIATED EQUIPMENT, COST OF CAPITAL OR LABOR, COST OF REPLACEMENT OR SUBSTITUTE PRODUCTS, OR LOSS OF TIME. IN THE EVENT THAT LEGEND ® SUSPENSIONS SHALL BE UNABLE TO REPAIR OR REPLACE THE PRODUCT AS REQUIRED HEREIN, THE LIABILITY OF LEGEND ® SUSPENSIONS TO YOU OR ANY OTHER PARTY SHALL NOT EXCEED THE PRICE ACTUALLY PAID BY YOU FOR THE PRODUCT, UPON THE PAYMENT OF WHICH, LEGEND ® SUSPENSIONS SHALL BE RELEASED FROM AND DISCHARGED OF ALL FURTHER OBLIGATIONS AND LIABILITY TO YOU.

THIS LIMITED WARRANTY GIVES YOU SPECIFIC LEGAL RIGHTS, AND YOU MAY ALSO HAVE OTHER RIGHTS THAT VARY FROM STATE TO STATE. SOME STATES DO NOT ALLOW THE EXCLUSION OR LIMITATION OF INCIDENTAL OR CONSEQUENTIAL DAMAGES, SO THE ABOVE LIMITATION OR EXCLUSION MAY NOT APPLY TO YOU.

### WARNING:

Legend Suspensions recommends this system be installed by a professional technician with professional knowledge of disassembly / reassembly procedures and post installation checks. Legend Suspensions are designed to be installed and used on **Unmodified Factory OEM Motorcycles only**.

Legend Suspensions assumes no responsibility for damage or injuries which may result from the use or installation of its products, whether or not properly installed or used. Installing Legend Suspensions' components may alter the geometry of your motorcycle by lowering or raising the vehicle's stock ride height, which may affect the handling characteristics of the motorcycle. The purchaser is responsible for verifying and maintaining proper and safe geometry of purchaser's motorcycle. Installing Legend Suspensions' components may decrease initial ground clearance when in lowered position. The motorcycle will be lower to the ground and care should be taken to avoid bottoming out, especially over bumps or in turns. Legend Suspensions recommends riding in the stock height position.

### Dispute Resolution

You agree that any dispute between you and Legend ® Suspensions arising hereunder will be resolved exclusively and finally by arbitration administered by the American Arbitration Association ("AAA") and conducted under its rules, except as otherwise provided below.

The arbitration will be conducted before a single arbitrator and will be limited solely to the dispute between you and Legend ® Suspensions. The arbitration shall be held at any reasonable location in Meade County, South Dakota, or by submission of documents, by telephone, online, or in person. Any decision rendered in such arbitration proceedings will be final and binding on each of the parties, and judgment may be entered thereon in any court of competent jurisdiction. Should either party bring a dispute in a forum other than AAA, the arbitrator may award the other party its reasonable costs and expenses, including attorney fees and disbursements incurred in staying or dismissing such other proceedings or in otherwise enforcing compliance with this dispute resolution provision.

YOU UNDERSTAND THAT YOU WOULD HAVE HAD A RIGHT TO LITIGATE DISPUTES THROUGH A COURT, AND THAT YOU HAVE EXPRESSLY AND KNOWINGLY WAIVED THAT RIGHT AND AGREED TO RESOLVE ANY DISPUTES THROUGH BINDING ARBITRATION.

For the purposes of this section, the term "dispute" means any dispute, controversy, or claim arising out of or relating to: (1) this Agreement, its interpretation, or the breach, termination, applicability, or validity thereof, or (2) the purchase or use of any Product, Accessory, service or otherwise from Legend ® Suspensions.

For purposes of this Agreement, the term Legend ® Suspensions means Legend ® Suspensions, its subsidiaries, affiliates, directors, officers, employees, beneficiaries, agents, or assigns; the term "you" means you, the original purchaser, your agents, beneficiaries, or heirs.

### Governing Law

Both you and Legend ® Suspensions consent to the application of the laws of the State of South Dakota to govern, interpret, and enforce all of your rights and Legend ® Suspensions' rights, duties, and obligations arising from, or relating in any manner to, the subject matter of this Limited Lifetime Warranty, without regard to conflict of law principles.

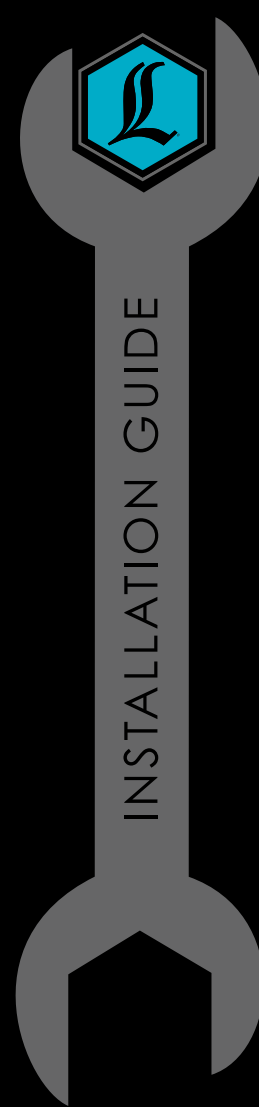

# REVO REVO-A

## FITMENT:

**13" REVO/REVO-A**  
**2009-2024 HARLEY-DAVIDSON**  
**TRIKE MODELS**

## NOTE:

**This suspension kit is compatible with Legend Lift Kits.**

### English

Please visit [www.legendsuspensions.com](http://www.legendsuspensions.com) for the translated version of this install guide in the following languages: French, German, Italian, and Spanish. Please choose your preferred language at the top of the page and then choose the product you purchased. The install guides are located on the bottom of the product page under Product Downloads.

### Spanish

Visite [www.legendsuspensions.com](http://www.legendsuspensions.com) para obtener la versión traducida de esta guía de instalación en los siguientes idiomas: francés, alemán, italiano y español. Elija su idioma de preferencia en la parte superior de la página y luego elija el producto que compró. Las guías de instalación se encuentran en la parte inferior de la página del producto, en la sección Descargas de productos.

### German

Besuchen Sie bitte [www.legendsuspensions.com](http://www.legendsuspensions.com) für die übersetzte Version dieser Installationsanleitung in den folgenden Sprachen: Französisch, Deutsch, Italienisch und Spanisch. Wählen Sie bitte oben auf der Seite Ihre bevorzugte Sprache und anschließend das von Ihnen gekaufte Produkt aus. Die Installationsanleitungen finden Sie am unteren Rand der Produktseite unter Produkt-Downloads.

### French

Veuillez visiter le site [www.legendsuspensions.com](http://www.legendsuspensions.com) pour la version traduite de ce guide d'installation dans les langues suivantes: français, allemand, italien et espagnol. Veuillez choisir votre langue préférée en haut de la page, puis choisissez le produit que vous avez acheté. Les guides d'installation sont disponibles au bas de la fiche produit sous Téléchargements de produits.

### Italian

Prego consultare [www.legendsuspensions.com](http://www.legendsuspensions.com) per la versione tradotta della presente guida di installazione nelle seguenti lingue: francese, tedesco, italiano, e spagnolo. Prego scegliere la lingua preferita in cima alla pagina e in seguito scegliere il prodotto acquistato. Le guide di installazione si trovano in fondo alla pagina di prodotto sotto Scaricamenti di Prodotti.

**Please scan the QR code to access product install guides and warranty in your selected language.**



# INSTALL INSTRUCTIONS

**WARNING:** When installing shocks that are different than the OEM length, confirm that the wheel travel can be altered without causing clearance issues. Failure to do so may result in damage to the trike due to contact between the swingarm / axle and the exhaust or contact between the tires and fenders.



## STEP ONE: REMOVE BODY

- A. Refer to the H-D Service Manual for removal instructions or take your trike to an authorized dealer FIGURE A.



## STEP TWO: REMOVE SHOCKS

- A. Properly support the trike on a jack.
- B. Remove the hydraulic preload adjuster from the frame (when applicable).
- C. Remove the upper shock bolts.
- D. Pivot the shocks slightly towards the rear of the trike to clear the upper shock mounts. Then lower the jack until access to remove the lower shock bolts is attained FIGURE B.
- E. Remove the shocks and hydraulic preload adjuster from the trike as a complete assembly. (Do not loosen or remove hoses on shocks or preload adjuster)



## STEP THREE: SET PRELOAD

**NOTE:** Preload adjustments are easier to make prior to installation using a bench vise and a set of soft jaws to hold the lower loop.

- A. Refer to the PRELOAD CHARTS on the insert sheet. If you are installing shocks on a Tri Glide Ultra, refer to CHART 1. If you are installing shocks on a Free Wheeler or Road Glide 3, refer to CHART 2.
- B. Determine the correct preload measurement based on the rider weight, plus the additional weight of the passenger, cargo, and accessories. This measurement will be taken from the base of the threaded spring seat to the flat surface on the lower loop FIGURE C.
- C. After both shocks have been adjusted, verify that measurements are the same to ensure that the springs are adjusted equally.



FIGURE A



FIGURE B

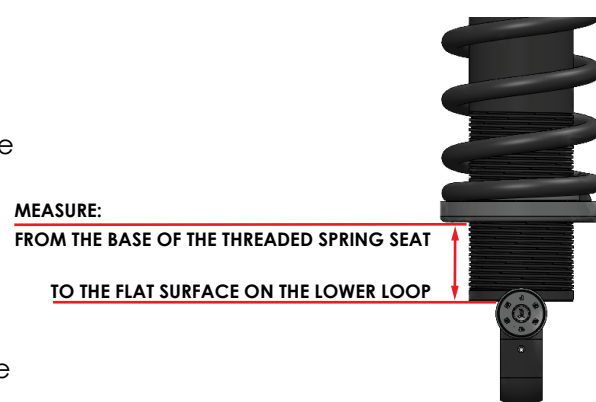

FIGURE C



## STEP FOUR: INSTALL SHOCKS

**NOTE:** If installing REVO-A's, install with the rebound adjusters facing the rear of the trike.

- A. Apply blue threadlocker to the supplied fasteners.
- B. Install the Legend shocks onto the lower mounts on the swingarm and torque the fasteners to 50 ft. lbs. FIGURE D
- C. Raise the jack until the shocks align with the upper mounts on the frame. Then install and torque the fasteners to 50 ft. lbs. FIGURE D
- D. Lower and remove the jack.

**IMPORTANT:** After the shocks are installed, make sure that you can rotate them freely in both directions FIGURE E.



## STEP FIVE: INSTALL BODY

- A. Install the body in the reverse order of removal in STEP ONE.



## STEP SIX: REBOUND DAMPING (APPLICABLE TO REVO-A)

- A. Rebound damping controls the speed at which the shock absorbers return to extended length after being compressed.
- B. If you feel the suspension has a bouncy or oscillating feel to it, increase the rebound damping to a larger number. If the suspension feels slow reacting or feels firm on closely spaced bumps, decrease the rebound damping to a smaller number.
- C. Set the rebound adjusters to the same number on both shocks. Test ride and make adjustments until the desired ride quality is achieved.

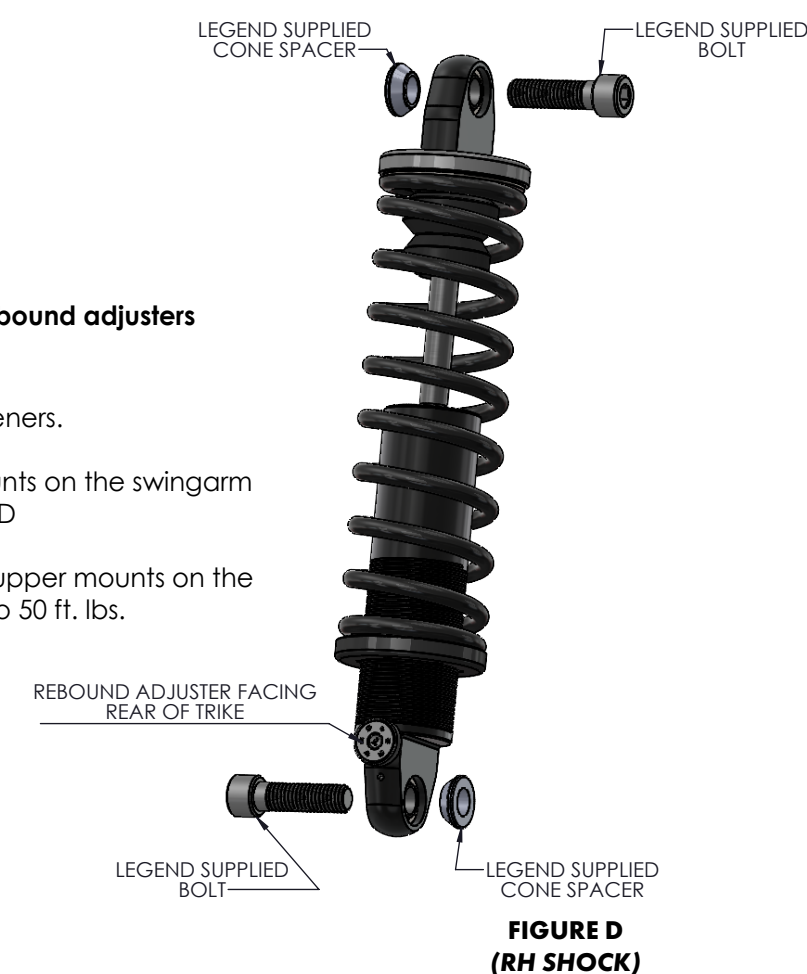

FIGURE D (RH SHOCK)



FIGURE E

**FINE TUNE REBOUND DAMPING: FOR LEGEND AIR-A AND REVO-A MODELS** MACHINED RECESS BELOW REBOUND ADJUSTER INDICATES REBOUND SETTING.

**SETTING 1:** Provides the lowest level of rebound damping.

**SETTING 3:** Provides an intermediate level of rebound damping.

**IMPORTANT:** This is the most commonly used setting.

**SETTING 6:** Provides the highest level of rebound damping.



MACHINED RECESS ON SHOCK